



PARS PANGAN COMPANY
Ball valve manufacturer





Content

Introduction

- 2 Company Overview
- 3 Design & Technology
- 4 Advanced Manufacturing
- 6 Quality Control

PRODUCTS

- 8 Floating Ball Valve
- 9 Design Feature
- 10 Material Specification
- 11 Dimension
- 12 Small Size Forged Floating Ball Valve
- 13 Material Specification
- 14 Trunnion Mounted Ball Valve
- 15 Design Feature
- 17 Split Body
- 19 Fully Welded
- 20 Material Specification
- 21 Dimension
- 26 Optional Features

Engineering Data

- 27 Torque Value & Mounting Flange Dimension
- 30 Applicable Standards
- 31 How to order



PARS PANGAN COMPANY

Ball valve manufacturer



PARSPANGAN Company which is an affiliated incorporation to the Petroleum Equipment Industries Company (PEIC) was established in 1998. It is the first and only IRANIAN company to design and produce industrial ball valves for Oil, Gas, Refinery, Chemical and Petrochemical Plants, Power Plants, Pipeline and ETC. Production activities of Parspangan is based on a strong technical knowledge transfer and Quality supervising of Famous Italian and German Companies. The organizational flexibility of the company allows prompt answering to any customer request in order to satisfy every requirement. Quality control during all phases of production, will assure our valued customers to reach their requirement according to the world wide standards.

The specific construction (characteristics) of the valves with Casting, Forging, Split Body Bolted Bonnet, Floating, Trunnion Mounted and Fully Welded types with different end connections with high quality material: PARS PANGAN production range includes industrial ball valves from 2" to 56" Class ANSI 150-300-600-900-1500 lb full and reduced bore in wide range of high quality material. PARS PANGAN facilities with 10,000 m² Workshops which include Assembly, Test and Machinery division located in Tehran, at Shams Abad industrial zone district in order to manufacturing large size ball valves (36" ~ 56") for the first time in Iran based on a contract with IGEDC.

Design & Technology

PARS PANGAN technical department conduct the calculations and design for valves according to customer need and relevant international standards such as API 6D, ASME B16.34, ASME B16.5.

All the valve components will be modeled with computer software like Mechanical Desktop and Solid Work.

PARS PANGAN engineering department operates the most advanced 3D CAD system and conducts Finite Element Analysis (FEA) to simulate various load conditions to determine components suitability for the intended service with aim of ANSYS and COSMOS Softwares.

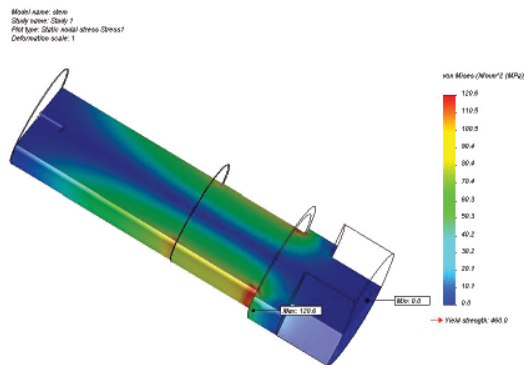

Stem – 20" Class 600 – Fully Welded Type

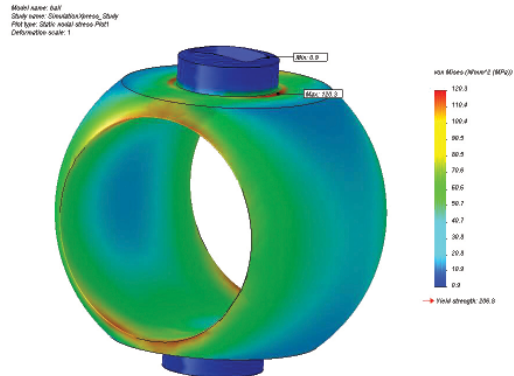

Ball – 20" Class 600 – Fully Welded Type

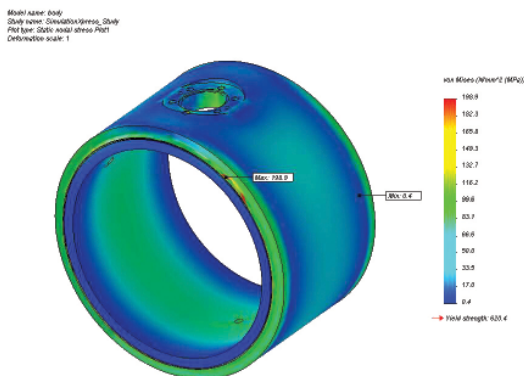

Body – 20" Class 600 – Fully Welded Type

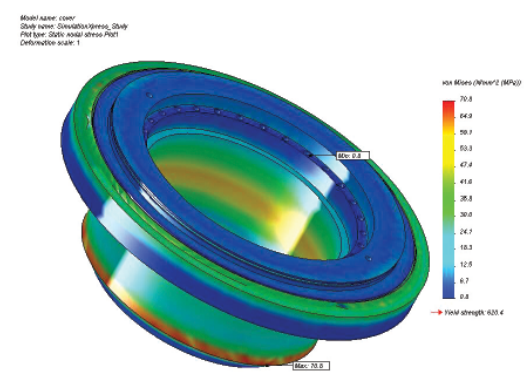

Cover – 20" Class 600 – Fully Welded Type



PARS PANGAN COMPANY

Ball valve manufacturer

Advanced Manufacturing

The latest computer technology was applied widely in PARS PANGAN for valve manufacturing. This includes numerical control machines (Machining Center, CNC Horizontal Lathe), Multi Spindle Drilling Machine.







PARS PANGAN COMPANY
Ball valve manufacturer

Quality Control

PARS PANGAN recognizes the importance of industrial valve quality for the safety and protection of personnel health and property. It is our quality commitment to focus our resources to provide our customers with the first class products at a competitive price, that are designed, Manufactured, inspected and tested in accordance with our customer's specifications which comply with all international standards.



Quality Control

PARS PANGAN ball valves are supplied with certified test reports, which include chemical and mechanical properties and the hydrostatic-pneumatic pressure tests and fire safe test.

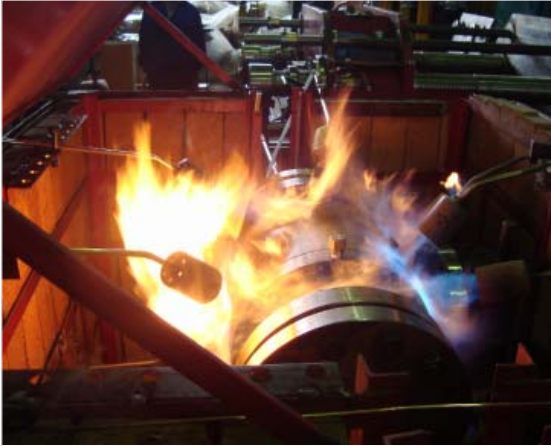

All valves (with no exception) (100%) pass through final hydrostatic and pneumatic test in accordance with international standard API 598 or API 6D or customer specifications before painting.





PARS PANGAN COMPANY

Ball valve manufacturer

Floating Ball Valve

PARSPANGAN Floating ball valves are casting two-piece, split body, side entry with flanged end body and floating ball design. All design conforms to BS EN ISO 17292 and API6D and fire safe are satisfied to BS 6755 part 2 and API 607 and API 6FA.

Wide range of material for body and trim is available for service working temperature from -46°C up to 200°C, from 2" to 8", In size full port or reduced port and pressure rating from ANSI class150 to 300 and for sour gas service to NACE MR-0175/ISO15156 is also available upon request.

A wide selection of soft seat material: PTFE, RPTFE, are available for different working pressure and temperature rating.

Blow out-proof stem, Anti-static device and Locking device are standard design ,low emission packing with live loaded gland flange design can be available upon request. Manual handle operation is basic standard ,but fully machined mounting pad can also easily install with gear, motor or pneumatic operator.

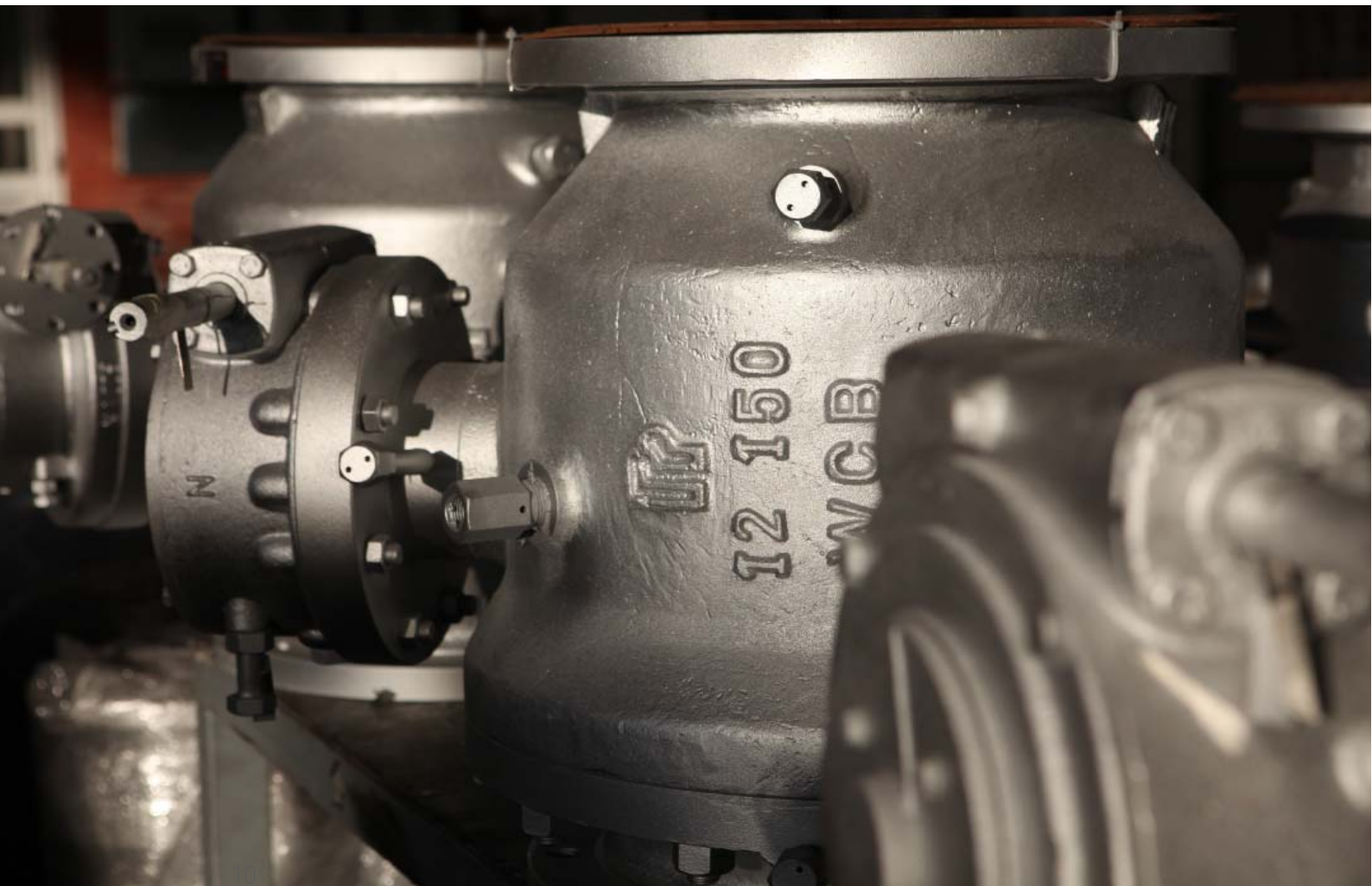

Floating Ball Valve / Design Feature

Blow-out Proof Stem

Stem lower end is integral "T" shaped designed to be blow-out proof. It is internally inserted and functions as the backseat for assured stem sealing at all pressures.

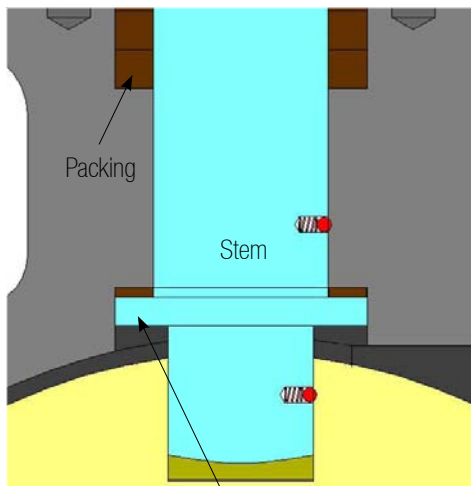

Blow Out Proof Stem

Anti-static Device

Anti static device is a standard feature of PARS PANGAN ball valve. A spring-loaded pin assures the electrical continuity, between ball, stem and body so as to avoid sparks during turning of the stem to open and close the valve, which could be dangerous in case of hazardous area installation.

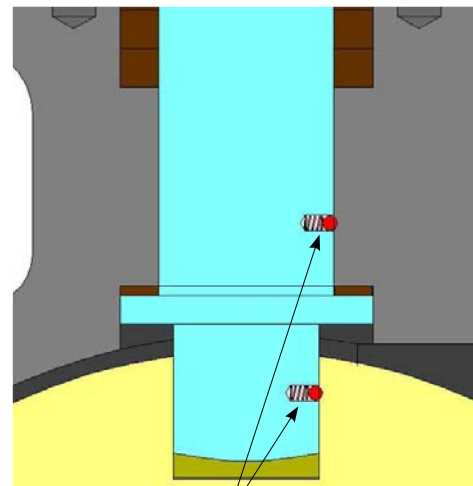

Anti Static Device

Fire Safe Seat Sealing

When non-metal sealing material are decomposed or deteriorated by a plant fire, the upstream line pressure pulls the ball into contact with metal seat lip on the body. Metal to Metal contact ball and body prevent internal leakage. All PARSPANGAN ball floating valves are fire safe designed and test certified in accordance with API 6FA.

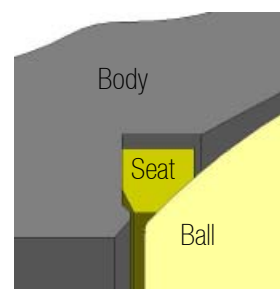

Before Fire

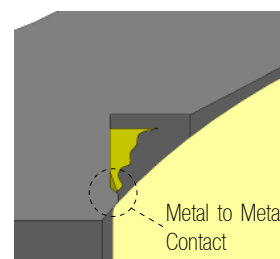

After Fire



PARS PANGAN COMPANY
Ball valve manufacturer

Floating Ball Valve / Material Specification

No. Part	Standard	Stainless Steel	Sour Service	Low Temperature Service
1 BODY	ASTM A216-WCB	ASTM A351-CF8M	ASTM A216-WCB	ASTM A352-LCB
2 COVER	ASTM A216-WCB	ASTM A351-CF8M	ASTM A216-WCB	ASTM A352-LCB
3 BALL	ASTM A105-ENP	ASTM A182-F316	ASTM A105-ENP	ASTM A182-F316
4 STEM	ASTM A182-F6a	ASTM A182 F316	ASTM A276-420	ASTM A182-F316
5 SEAT RING	PTFE	PTFE	PTFE	PTFE
6 STEM SEAL	PTFE	PTFE	PTFE	PTFE
7 STEM PACKING	GRAPHITE	GRAPHITE	GRAPHITE	GRAPHITE
8 THRUST WASHER	PTFE	PTFE	PTFE	PTFE
9 GLAND RING	ASTM A276-420	ASTM A182-F316	ASTM A182-F6a	ASTM A182-F316
10 STOP PLATE	Carbon Steel	S.S.	Carbon Steel + Zn	Carbon Steel + Zn
11 SPACER	Carbon Steel	S.S.	Carbon Steel + Zn	Carbon Steel + Zn
12 LOAD SPRING	Carbon Steel	Carbon Steel	Carbon Steel	Carbon Steel
13 GLAND NUT	Carbon Steel	S.S.	Carbon Steel + Zn	Carbon Steel + Zn
14 LEVER	Carbon Steel	Carbon Steel	Carbon Steel	Carbon Steel
15 PIPE	Carbon Steel	Carbon Steel	Carbon Steel	Carbon Steel
16 BOLT	Carbon Steel	S.S.	Carbon Steel + Zn	Carbon Steel + Zn
17 SCREW	Carbon Steel	S.S.	Carbon Steel + Zn	Carbon Steel + Zn
18 STOP PIN	Carbon Steel	S.S.	Carbon Steel + Zn	Carbon Steel + Zn
19 BALL ANTI-STATIC	S.S.	S.S.	S.S.	S.S.
20 SPRING ANTI-STATICS.S.	S.S.	S.S.	S.S.	S.S.
21 BODY GASKET	316SS+Graphite	316SS+Graphite	316SS+Graphite	316SS+Graphite
22 STUD	ASTM A193-B7	ASTM A193-B8	ASTM A193-B7M	ASTM A320-L7M
23 NUT	ASTM A194-2H	ASTM A194-8	ASTM A194-2HM	ASTM A194-7M

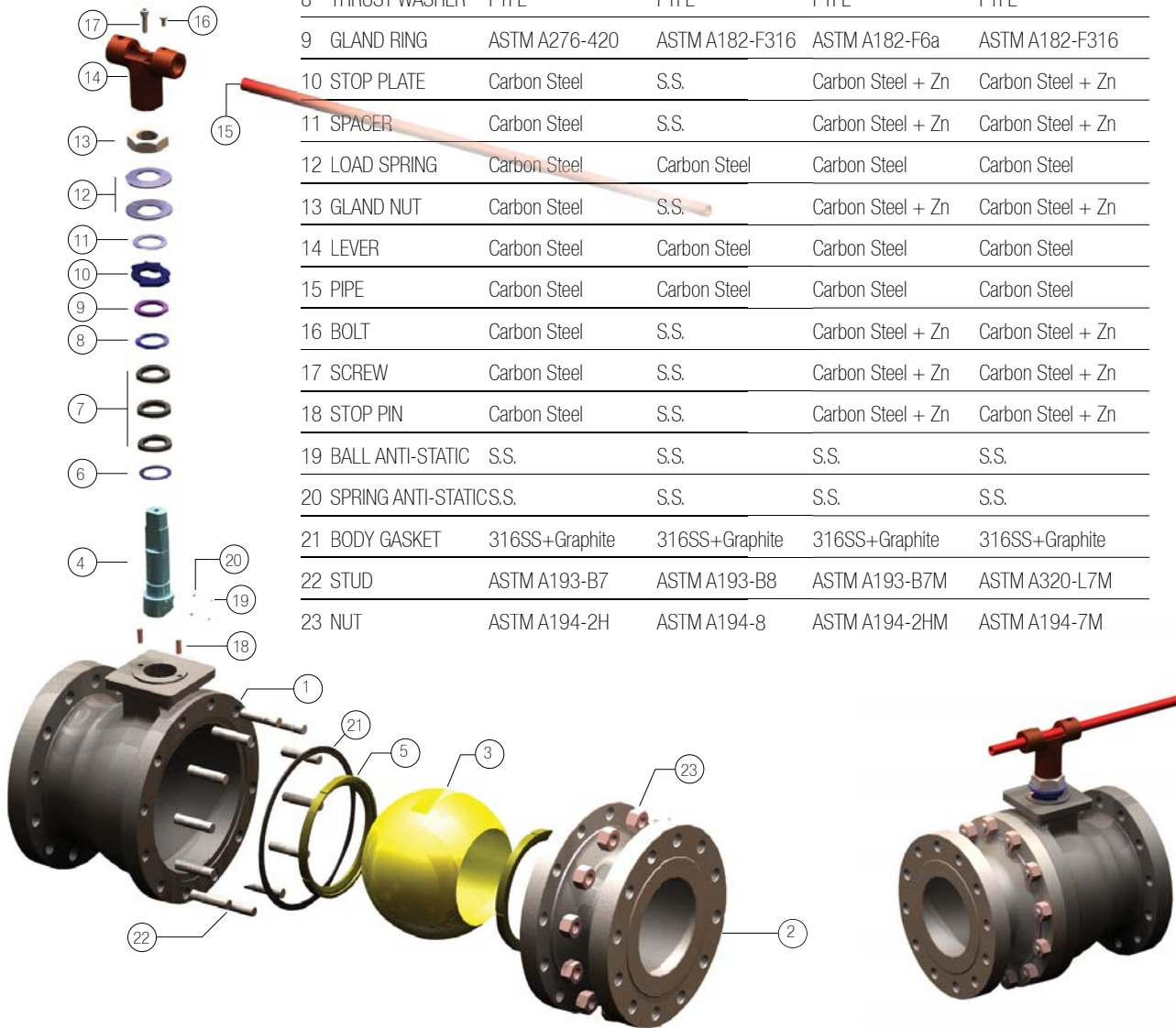

Floating Ball Valve / Dimension



FULL BORE						CLASS 150
ALL TYPES			DIMENSION			WEIGHT
SIZE	D	d	L-RF	H	L1	RF
in	mm	mm	mm	mm	mm	KG
2	51	51	178	183	285	9.5
3	76	76	203	217	285	19
4	102	102	229	243	285	33
6	152	152	394	284	750	93
8	203	203	457	340	800*	160

REDUCED BORE						CLASS 150
ALL TYPES			DIMENSION			WEIGHT
SIZE	D	d	L-RF	H	L1	RF
in	mm	mm	mm	mm	mm	KG
2x1-1/2	51	38	178	123	285	9.5
3x2	76	51	203	186	285	19
4x3	102	76	229	230	285	33
6x4	152	102	394	260	750	58
8x6	203	152	457	300	800*	93

FULL BORE						CLASS 300
ALL TYPES			DIMENSION			WEIGHT
SIZE	D	d	L-RF	H	L1	RF
in	mm	mm	mm	mm	RF	KG
2	51	51	216	123	285	15
3	76	76	283	138	285	35
4	102	102	305	161	430	56
6*	152	152	403	234	800	115
8*	203	203	502	259	850*	134

FULL BORE						CLASS 300
ALL TYPES			DIMENSION			WEIGHT
SIZE	D	d	L-RF	H	L1	RF
in	mm	mm	mm	mm	mm	KG
2x1-1/2	51	38	216	123	285	15
3x2	76	51	283	186	285	30
4x3	102	76	305	230	340	56
6x4	152	102	403	260	430	82
8x6*	203	152	502	300	800*	120

* Gear Box



PARS PANGAN COMPANY

Ball valve manufacturer

Small Size Forged Floating Ball Valve

PARS PANGAN small size floating ball valves are forged two & three-piece, split body, side entry with flanged, Screwed and Socket weld end connections and floating ball design. All designs conform to BS EN ISO 17292 and API6D and fire safe are satisfied to API 6FA and API 607 and BS 6755. And for sour gas services according to NACE MR-0175/ISO15156 is also available upon request.

The available sizes are 1/4" to 1.1/2" full and reduced port and pressure rating from ANSI class150 to 2500. Wide range of body and trim materials are available.



Small Size Forged Floating Ball Valve / Material Specification

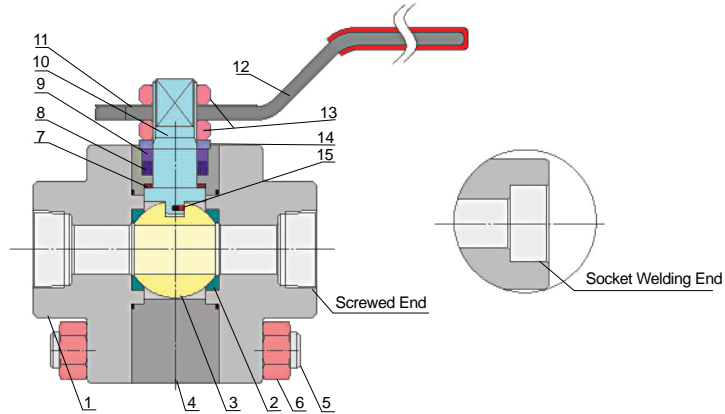

Features	Specification
Class: ANSI 800 ~ 1500	Design: ASME B16.34 / BS EN ISO 17292
Two & Three Pieces Forged Steel Body	End to End: Manufacturer Standard
Floating Ball, Full Bore, Reduced Bore	Screwed End: ASME B1.20.1
Anti-Static Device	Socketed Welding End: ASME B16.11
Fire Safe Design	Test: API 598/BS 6755
Anti Blow Out Stem	Special: NACE MR-0 175 / ISO 15156

No.	Part	Standard Trim	Stainless Steel Trim	Sour Service	Low Temperature Service
1	Bonnet	A105	A182 F316	A105	A350 LF2
2	Seat	RPTFE	RPTFE	RPTFE	RPTFE
3	Ball	A105+ENP	A182 F316	A182 F316	A182 F316
4	Body	A105	A182 F316	A105	A350 LF2
5	Stud	A193 B7	A193 B7	A193 B7M	A194 7M
6	Nut	A194 2H	A194 2H	A194 2HM	A320 L7M
7	Thrust Washer	RPTFE	RPTFE	RPTFE	RPTFE
8	Packing	Graphite	Graphite	Graphite	Graphite
9	Gland	A105	A105	A105	A105
10	Stem	A105+ENP	A182 F316	A105+ENP	A350 LF2+ENP
11	Name Plate	S.S.	S.S.	S.S.	S.S.
12	Lever	A216 WCB	A216 WCB	A216 WCB	A216 WCB
13	Nut	A194 2H	A194 2H	A194 2HM	A320 L7M
14	Load Spring	Carbon Steel	Carbon Steel	Carbon Steel	Carbon Steel
15	Anti Static	S.S.	S.S.	S.S.	S.S.



PARS PANGAN COMPANY

Ball valve manufacturer

Trunnion Mounted Ball Valve

PARS PANGAN Trunnion mounted ball valves with

- Anti-static device
- anti-blow out proof stem
- double block and bleed
- Sealant injection facilities of stem & seats.
- venting and drain fittings
- and Trunnion bearings to assure low operating torque throughout entire valve life

Contains 2 main series:

- 1- Cast steel two-piece design
- 2- and forged steel three-piece design (Split body and Fully welded body)

All designs conform to API 6D and fire safe test are satisfied to BS 6755 and API 6FA or API 607.

Emergency sealing system at stem and seat area, and

safety relieve valve in case of cavity over pressure are other features for our valves completely satisfy our customers' requirements with high quality products.

The available sizes are 2" to 48". Also sizes of 56" are going to be manufactured with technical support of a European reputable valve manufacturer from 2012. Wide range of body and trim materials are available for different services and working temperatures from -46°C to 200°C and pressure from ANSI class 150 to 1500 or for sour service according to NACE MR 0175 / ISO15156.



Trunnion Mounted Ball Valve / Design Feature

Anti Blow-out Stem

The stem is made separately from the ball; the lower end of the stem is designed with an integral collar to be blow-out proof.

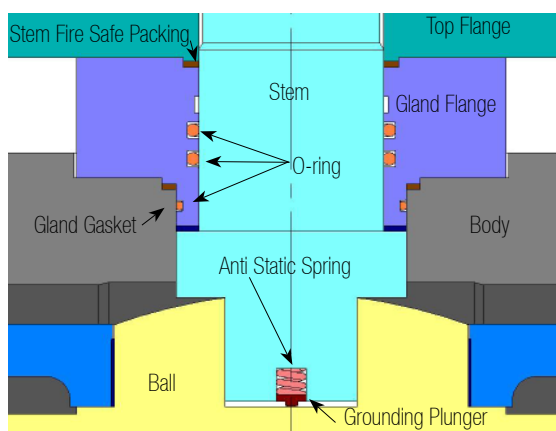

Anti-static Device

Antistatic device is a standard feature of PARS PANGAN ball valve. A spring-loaded pin assures the electrical continuity between ball, stem and body, so as to avoid sparks during turning of the stem to open and close the valve, which could be dangerous in case of hazardous area installation.

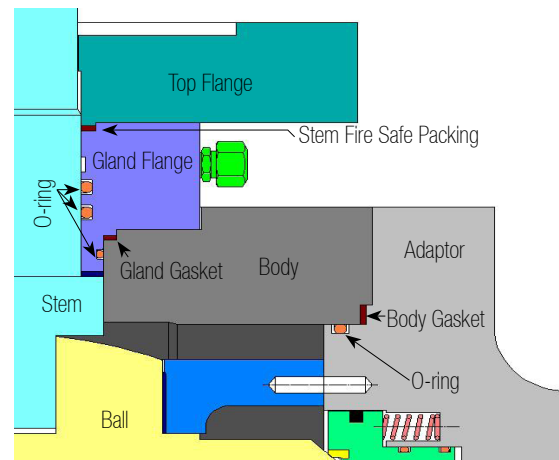

Fire safe design

External leakage prevention

Leakage from the valve stem area is prevented by double sealing with 2 O-ring and gland gasket. Leakage through the valve body joint is also blocked by double sealing with O-ring and body gasket. After a fire has deteriorated O-rings, gland gasket, body gasket and stem fire safe packing are the measure that prevents external fluid leakage.

Internal leakage prevention

When non-metal materials such as O-ring, seat insert and spacer are decomposed or deteriorated by fire, the edge of the metal seat preloaded by the seat spring comes into contact with the ball to shut off the line fluid to minimize internal leakage through the valve bore. Also the fire safe flexible graphite seat packing will be compressed by the seat spring to prevent fluid leakage between the valve body and seat.

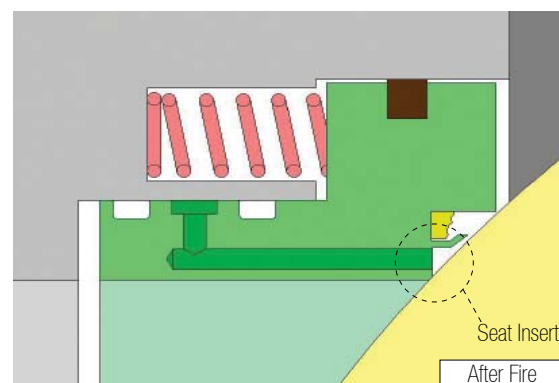
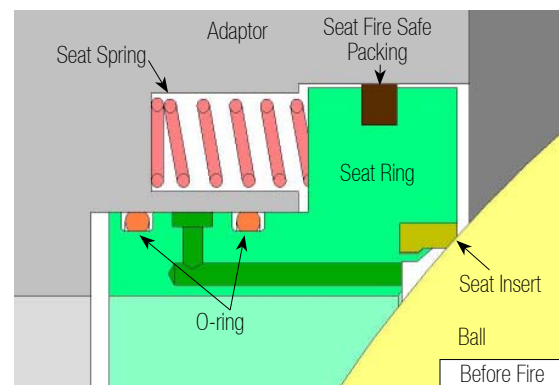



PARS PANGAN COMPANY
Ball valve manufacturer

Trunnion mounted Ball Valve / Design Feature

Emergency sealant injection system

For 6 inch and large PARS PANGAN Trunnion mounted ball valves will be installed with a sealant injection fitting on stem and seats. When the sealing materials (seat sealing or stem o-ring) are damaged, leakage from the seat and stem can be prevented by injection of sealant into these fittings. Fitting also internally installed a second check valve to provide backup sealing.

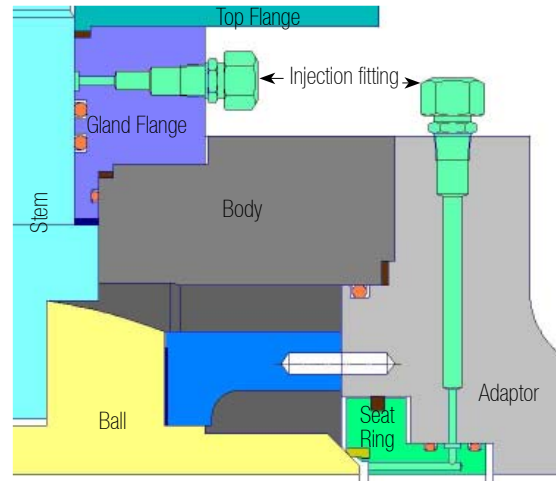

Double block and bleed

Each ball seats shut off the line fluid independently on the upstream and downstream side, allowing double block operation. When the pressure is simultaneously applied to both sides of the ball in closed position, the valve bore and the body cavity will be isolated from each other, and the residue within the body cavity can be released through the drain plug.

and line pressure (P_l), i.e. $\Delta P \cdot D_1 < F_s$, then contact between ball and seat ring is assure to provide a tight seal. When cavity pressure is higher than seat spring force and line pressure, i.e. $\Delta P \cdot D_1 > F_s$, the self relieving action allows that valve seat will move slightly away from the ball surface, therefore any over pressure acting in the body cavity is discharged into the line to restore the balance between the body cavity and line (either upstream or downstream).

Cavity pressure relief

When cavity pressure (P_c) is lower than seat spring force

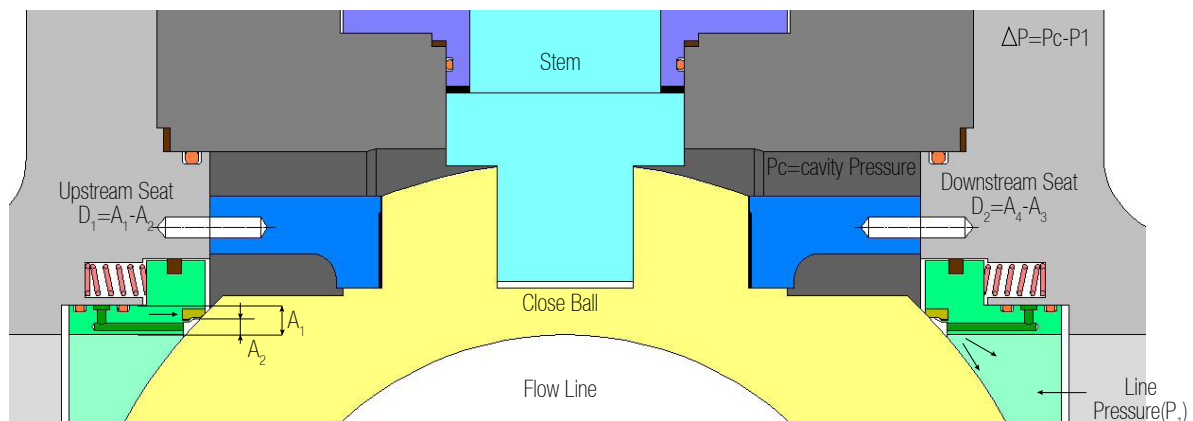

Trunnion Mounted Ball Valve / 2pcs. Split Body

No.	Part
1	BODY
2	COVER
3	BALL
4	SEAT RING
5	SEAT INSERT
6	STEM
7	GLAND CAP
8	TOP FLANGE
9	TRUNNION SUPPORT
10	SEAT SPRING
11	SEAT O-RING
12	BODY O-RING
13	STEM O-RING
14	GLAND O-RING
15	BODY GASKET
16	GLAND GASKET

No.	Part
17	GASKET
18	BEARING
19	TRUNNION PIN
20	FIRE SAFE GASKET
21	THRUST WASHER
22	SHIM
23	DRAIN
24	SEAT INJECTION
25	BODY VENT
26	STEM INJECTION
27	SCREW
28	GLAND PIN
29	SCREW
30	PLUNGER
31	SPRING
32	STUD
33	NUT

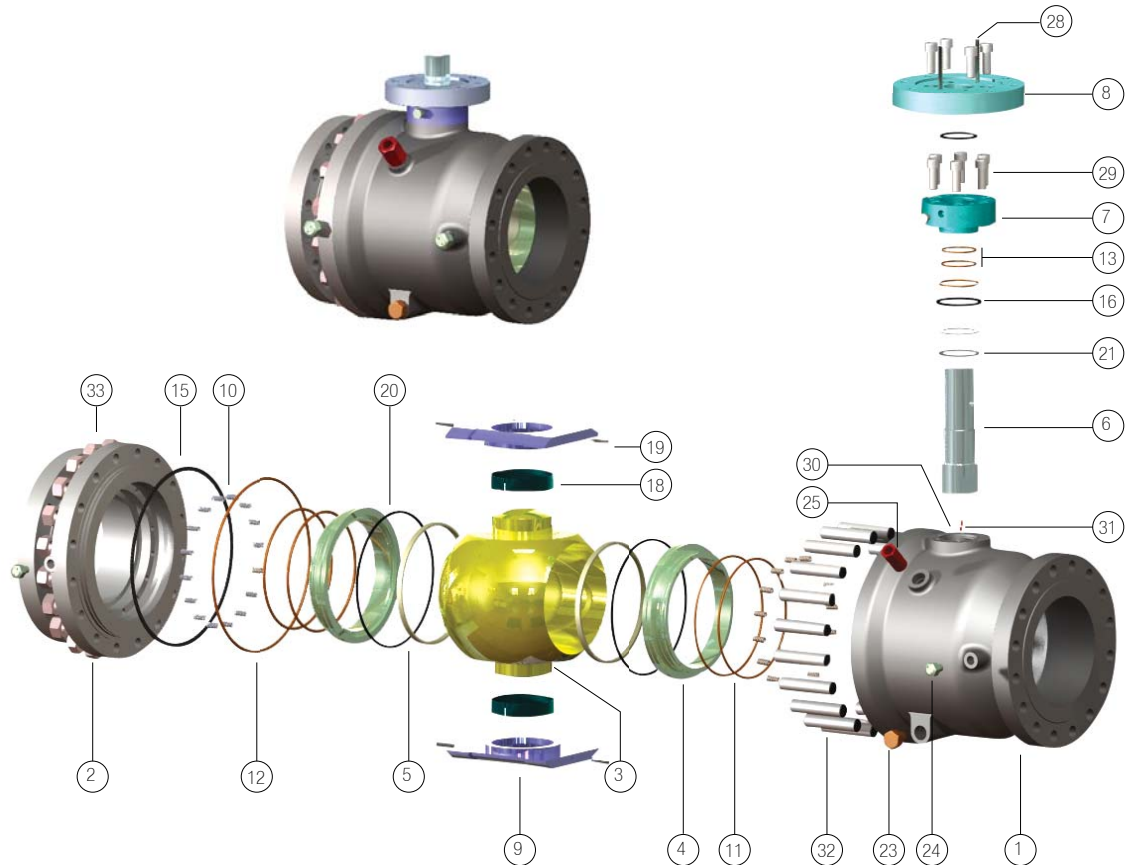



PARS PANGAN COMPANY

Ball valve manufacturer

Trunnion Mounted Ball Valve / 3pcs.Split Body

No.	Part	No.	Part
1	BODY	18	BEARING
2	CLOSURE	19	TRUNNION PIN
3	BALL	20	FIRE SAFE GASKET
4	SEAT RING	21	THRUST WASHER
5	SEAT INSERT	22	SHIM
6	STEM	23	DRAIN
7	GLAND CAP	24	SEAT INJECTION
8	TOP FLANGE	25	BODY VENT
9	TRUNNION SUPPORT	26	STEM INJECTION
10	SEAT SPRING	27	SCREW
11	SEAT O-RING	28	GLAND PIN
12	BODY O-RING	29	SCREW
13	STEM O-RING	30	PLUNGER
14	GLAND O-RING	31	SPRING
15	BODY GASKET	32	STUD
16	GLAND GASKET	33	NUT
17	GASKET	34	LIFTING LUG
		35	SUPPORT LEG

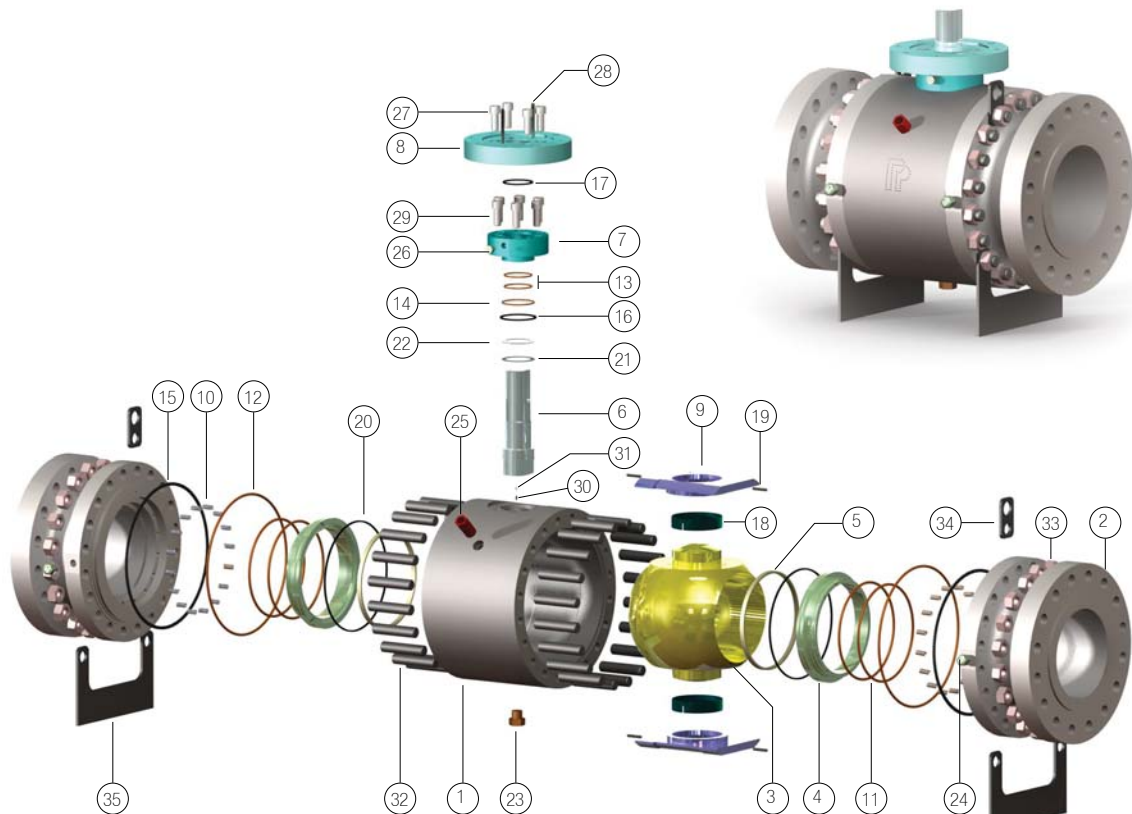

Trunnion Mounted Ball Valve / Fully Welded

No.	Part
1	BODY
2	CLOSURE
3	BALL
4	SEAT RING
5	SEAT INSERT
6	STEM
7	GLAND CAP
8	TOP FLANGE
9	TRUNNION SUPPORT
10	SEAT SPRING
11	SEAT O-RING
12	BODY O-RING
13	STEM O-RING
14	GLAND O-RING
15	GLAND GASKET

No.	Part
16	GASKET
17	BEARING
18	TRUNNION PIN
19	FIRE SAFE GASKET
20	THRUST WASHER
21	DRAIN
22	SEAT INJECTION
23	BODY VENT
24	STEM INJECTION
25	SCREW
26	GLAND PIN
27	SCREW
28	PLUNGER
29	LIFTING LUG
30	SUPPORT LEG

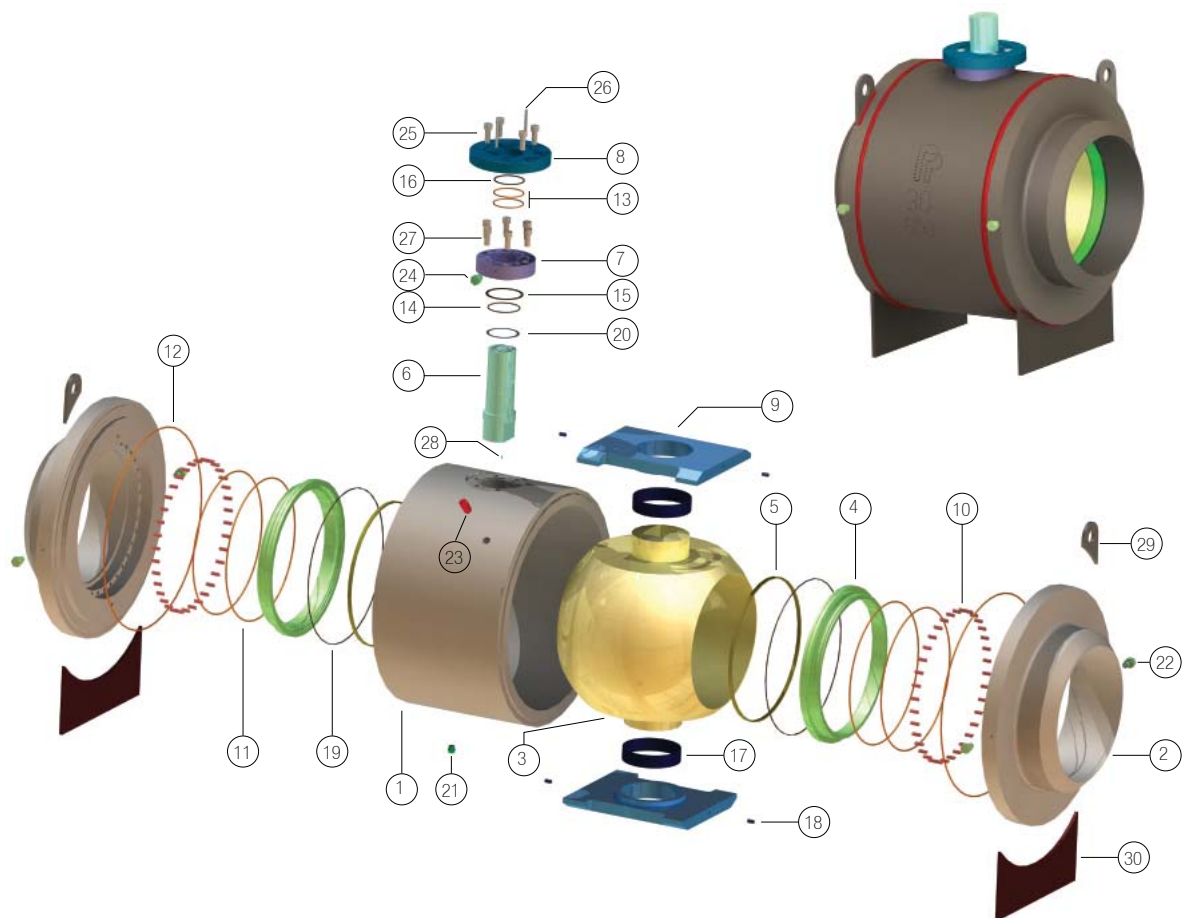



PARS PANGAN COMPANY

Ball valve manufacturer

Trunnion Ball Valve / Material Specification

No.	Part	Standard	Stainless Steel	Sour Service	Low Temperature Service
1	BODY	ASTM A105	ASTM A182-F316	ASTM A105	ASTM A350-LF2
2	CLOSURE	ASTM A105	ASTM A182-F316	ASTM A105	ASTM A350-LF2
3	BALL	ASTM A105-ENP	ASTM A182-F316	ASTM A105-ENP	ASTM A350-LF2/ENP
4	SEAT RING	ASTM A105-ENP	ASTM A182-F316	ASTM A105-ENP	ASTM A350-LF2/ENP
5	SEAT INSERT	25%Glass-filled PTFE	25%Glass-filled PTFE	25%Glass-filled PTFE	25%Glass-filled PTFE
6	STEM	ASTM A105-ENP	ASTM A182-F316	ASTM A105-ENP	ASTM A350-LF2/ENP
7	TOP FLANGE	ASTM A105	ASTM A182-F316	ATM A105	ASTM A350-LF2
8	TRUNNION SUPPORT	ASTM A216-WCB/ENP	ASTM A351-CF8M	ASTM A216-WCB/ENP	ASTM A352-LCB/ENP
9	SEAT SPRING	Inconel X-750	Inconel X-750	Inconel X-750	Inconel X-750
10	SEAT ORING	VITON	VITON	VITON	VITON
11	STEM ORING	VITON	VITON	VITON	VITON
12	GLAND ORING	VITON	VITON	VITON	VITON
13	GLAND GASKET	Graphite	Graphite	Graphite	Graphite
14	FIRE SAFE GASKET	Graphite	Graphite	Graphite	Graphite
15	THRUST WASHER	316+PTFE+MoS2	316+PTFE+MoS2	316+PTFE+MoS2	316+PTFE+MoS2
16	SHIM	ASTM A182-F316	ASTM A182-F316	ASTM A182-F316	ASTM A182-F316
17	DRAIN	S.S.	S.S.	S.S.	S.S.
18	INJECTION	Assembly	Assembly	Assembly	Assembly
19	GLAND PIN	Carbon steel	S.S.	Carbon steel	Carbon steel
20	PLUNGER	ASTM A182-F316	ASTM A182-F316	ASTM A182-F316	ASTM A182-F316
21	STUD	ASTM A193-B7	ASTM A193-B8	ASTM A193-B7M	ASTM A320-L7M
22	NUT	ASTM A194-2H	ASTM A194-8	ASTM A194-2HM	ASTM A194-7M
23	TOP FLANGE GASKET	Graphite	Graphite	Graphite	Graphite
24	SPACER	PTFE	PTFE	PTFE	PTFE
25	KEY	Carbon steel	S.S.	Carbon steel	ASTM A182-F304

Trunnion Mounted Ball Valve / Dimension

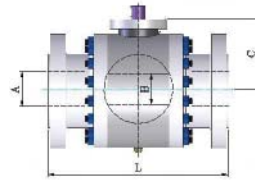
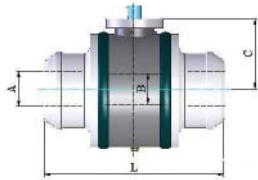

FULL BORE						CLASS 150			
ALL TYPES		SPLIT BODY & WELDED BODY				WEIGHT			
SIZE	A	B	L-RF	L-BW	C	SPLIT BODY		WELDED BODY	
in	mm	mm	mm	mm	mm	RF	BW	RF	BW
2	51	51	178	216	123	30		*	*
3	76	76	203	283	138	60		*	*
4	102	102	229	305	161	92		*	*
6	152	152	394	457	234	190		*	*
8	203	203	457	521	259	345		*	*
10	254	254	533	559	314	495		*	*
12	305	305	610	635	366	705		*	*
14	337	337	686	762	415	859		*	*
16	387	387	762	838	442	1020		*	*
18	438	438	864	914	476	1440		*	*
20	489	489	914	991	605	1918		*	*
22	540	540	991	1092	685	2352		*	*
24	591	591	1067	1143	745	3180		*	*
26	635	635	1143	1245	625	3770		*	*
30	736	736	1295	1397	720	5370		*	*

REDUCED BORE						CLASS 150			
ALL TYPES		SPLIT BODY & WELDED BODY				WEIGHT			
SIZE	A	B	L-RF	L-BW	C	SPLIT BODY		WELDED BODY	
in	mm	mm	mm	mm	mm	RF	BW	RF	BW
2x1-1/2	51	38	178	216	123	30		*	*
3x2	76	51	203	283	138	60		*	*
4x3	102	76	229	305	161	92		*	*
6x4	152	102	394	457	234	190		*	*
8x6	203	152	457	521	259	345		*	*
10x8	254	203	533	559	314	495		*	*
12x10	305	254	610	635	366	705		*	*
14x12	337	305	686	762	415	859		*	*
16x14	387	337	762	838	442	1020		*	*
18x16	438	387	864	914	476	1440		*	*
20x18	489	438	914	991	605	1918		*	*
22x20	540	489	991	1092	685	2352		*	*
24x20	591	489	1067	1143	745	2803		*	*
26x24	636	591	1143	1245	625	3200		*	*
30x24	736	591	1295	1397	720	3430		*	*

* For weight consult the PARS PANGAN



PARS PANGAN COMPANY

Ball valve manufacturer

Trunnion Ball Valve / Dimension

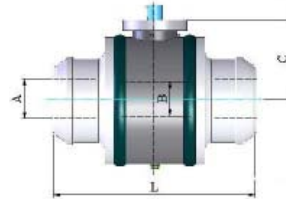
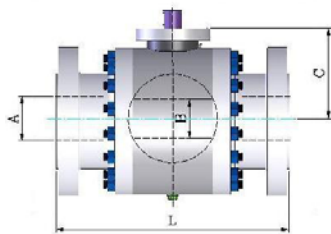

FULL BORE						CLASS 300			
SIZE	ALL TYPES		SPLIT BODY & WELDED BODY			WEIGHT			
	A	B	L-RF	L-BW	C	SPLIT BODY		WELDED BODY	
in	mm	mm	mm	mm	mm	RF	BW	RF	BW
2	51	51	216	216	123	31		*	*
3	76	76	283	283	138	69		*	*
4	102	102	305	305	166	111		*	*
6	152	152	403	457	234	211		*	*
8	203	203	502	521	259	376		*	*
10	254	254	568	559	327	540		*	*
12	305	305	648	635	376	763		*	*
14	337	337	762	762	415	900		*	*
16	387	387	838	838	480	1300		*	*
18	438	438	914	914	576	1715		*	*
20	489	489	991	991	650	2090		*	*
22	540	540	1092	1092	750	2220		*	*
24	591	591	1143	1143	820	3610		*	*
26	635	635	1245	1245	950	4810		*	*
30	737	737	1397	1397	1035	6740		*	*

REDUCED BORE						CLASS 300			
SIZE	ALL TYPES		SPLIT BODY & WELDED BODY			WEIGHT			
	A	B	L-RF	L-BW	C	SPLIT BODY		WELDED BODY	
in	mm	mm	mm	mm	mm	RF	BW	RF	BW
2x1-1/2	51	38	216	216	123	30		*	*
3x2	76	51	283	283	138	37		*	*
4x3	102	76	305	305	166	74		*	*
6x4	152	102	403	457	234	142		*	*
8x6	203	152	502	521	259	253		*	*
10x8	254	203	568	559	327	410		*	*
12x10	305	254	648	635	376	580		*	*
14x12	337	305	762	762	415	830		*	*
16x14	387	337	838	838	480	970		*	*
18x16	438	387	914	914	576	1530		*	*
20x18	489	438	991	991	650	1830		*	*
22x20	540	489	1092	1092	750	2010		*	*
24x20	591	489	1143	1143	820	2750		*	*
26x24	635	591	1245	1245	820	4050		*	*
30x24	737	591	1397	1397	820	4630		*	*

*For weight consult the PARS PANGAN

Trunnion Mounted Ball Valve / Dimension

FULL BORE						CLASS 600			
ALL TYPES			SPLIT BODY & WELDED BODY			WEIGHT			
SIZE	A	B	L-RF	L-BW	C	SPLIT BODY		WELDED BODY	
in	mm	mm	mm	mm	mm	RF	BW	RF	BW
2	51	51	292	292	123	31		*	*
3	76	76	356	356	138	69		*	*
4	102	102	432	432	166	111		*	*
6	152	152	559	559	234	250		*	*
8	203	203	660	660	259	485		*	*
10	254	254	787	787	327	760		*	*
12	305	305	838	838	376	1070		*	*
14	337	337	889	889	415	1100		*	*
16	387	387	991	991	480	1550		*	*
18	438	438	1092	1092	576	2180		*	*
20	489	489	1194	1194	650	2750		*	*
22	540	540	1295	1295	750	3850		*	*
24	591	591	1397	1397	820	4800		*	*
26	635	635	1448	1448	675	5800		*	*
30	737	737	1651	1651	780	8500		*	*
36	874	874	2083	2083	870	13530		*	*
42	1020	1020	2200	2200	1060	21590		*	*
48	1168	1168	2300	2300	1128	*		*	25000
56	1361	1361	2500	2500	1300	*		*	35000

REDUCED BORE						CLASS 600			
ALL TYPES			SPLIT BODY & WELDED BODY			WEIGHT			
SIZE	A	B	L-RF	L-BW	C	SPLIT BODY		WELDED BODY	
in	mm	mm	mm	mm	mm	RF	BW	RF	BW
2x1-1/2	51	38	292	292	123	30		*	*
3x2	76	51	356	356	138	37		*	*
4x3	102	76	432	432	166	74		*	*
6x4	152	102	559	559	234	155		*	*
8x6	203	152	660	660	259	310		*	*
10x8	254	203	787	787	327	570		*	*
12x10	305	254	838	838	376	850		*	*
14x12	337	305	889	889	415	950		*	*
16x14	387	337	991	991	480	1100		*	*
18x16	438	387	1092	1092	576	1700		*	*
20x18	489	438	1194	1194	650	2450		*	*
22x20	540	489	1295	1295	750	3200		*	*
24x20	591	489	1397	1397	820	3390		*	*
26x24	635	591	1448	1448	820	5000		*	*
30x24	737	635	1651	1651	820	5910		*	*
36x30	874	737	2083	2083	850	10560		*	*

* For weight consult the PARS PANGAN



PARS PANGAN COMPANY

Ball valve manufacturer

Trunnion Ball Valve / Dimension

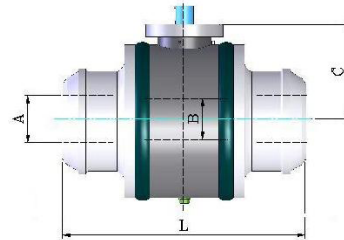
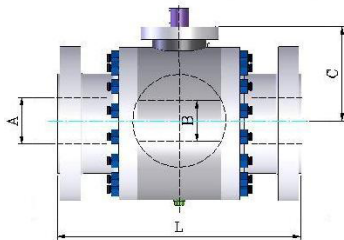

FULL BORE						CLASS 900			
ALL TYPES		SPLIT BODY & WELDED BODY				WEIGHT (Kg)			
SIZE	A	B	L-RF	L-BW	C	SPLIT BODY		WELDED BODY	
in	mm	mm	mm	mm	mm	RF	BW	RF	BW
2	51	51	368	368	140	52		*	*
3	76	76	381	381	179	80		*	*
4	102	102	457	457	201	170		*	*
6	152	152	610	610	267	390		*	*
8	203	203	737	737	312	650		*	*
10	254	254	838	838	350	1070		*	*
12	305	305	965	965	407	1610		*	*
14	324	324	1029	1029	398	1560		*	*
16	375	375	1130	1130	457	2250		*	*
18	425	425	1219	1219	484	3000		*	*
20	473	473	1321	1321	516	4500		*	*
24	572	572	1549	1549	567	7050		*	*
30	714	714	1880	1880	1000	12500		*	*

REDUCED BORE						CLASS 900			
ALL TYPES		SPLIT BODY & WELDED BODY				WEIGHT (Kg)			
SIZE	A	B	L-RF	L-BW	C	SPLIT BODY		WELDED BODY	
in	mm	mm	mm	mm	mm	RF	BW	RF	BW
2x1-1/2	51	38	368	368	103	45		*	*
3x2	76	51	381	381	138	56		*	*
4x3	102	76	457	457	166	105		*	*
6x4	152	102	610	610	234	226		*	*
8x6	203	152	737	737	259	480		*	*
10x8	254	203	838	838	327	700		*	*
12x10	305	254	965	965	376	1200		*	*
14x12	324	305	1029	1029	415	1300		*	*
16x14	375	324	1130	1130	480	1800		*	*
18x16	425	375	1219	1219	576	2520		*	*
20x18	473	425	1321	1321	650	3400		*	*
24x20	572	473	1549	1549	820	5600		*	*
30x24	714	572	1880	1880	570	9000		*	*

*For weight consult the PARS PANGAN

Trunnion Mounted Ball Valve / Dimension

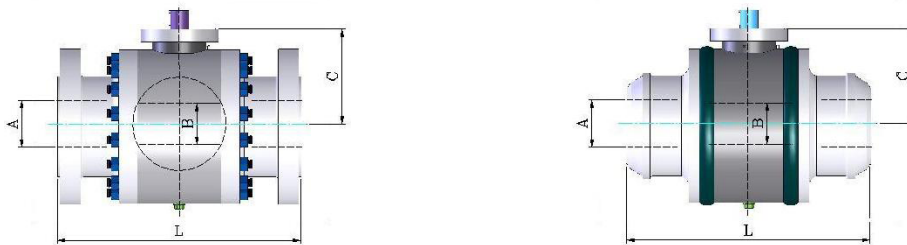

FULL BORE						CLASS 1500			
ALL TYPES		SPLIT BODY & WELDED BODY				WEIGHT			
SIZE	A	B	L-RF	L-BW	C	SPLIT BODY		WELDED BODY	
in	mm	mm	mm	mm	mm	RF	BW	RF	BW
2	51	51	368	368	139	60		*	*
3	76	76	470	470	187	115		*	*
4	102	102	546	546	225	200		*	*
6	146	146	705	705	273	580		*	*
8	194	194	832	832	310	752		*	*
10	241	241	991	991	363	1560		*	*
12	289	289	1130	1130	421	1970		*	*
14	318	318	1257	1257	437	3000		*	*
16	362	362	1384	1384	475	4260		*	*
18	407	407	1537		563	6400		*	*
20	457	457	1664		617	9300		*	*
24	546	534	2045		698	14550		*	*

REDUCED BORE						CLASS 1500			
ALL TYPES		SPLIT BODY & WELDED BODY				WEIGHT			
SIZE	A	B	L-RF	L-BW	C	SPLIT BODY		WELDED BODY	
in	mm	mm	mm	mm	mm	RF	BW	RF	BW
2x1-1/2	51	38	368	368	139	56		*	*
3x2	76	51	381	381	187	82		*	*
4x3	102	76	457	457	225	150		*	*
6x4	152	102	610	610	273	295		*	*
8x6	203	152	737	737	310	690		*	*
10x8	254	203	838	838	363	1200		*	*
12x10	305	254	965	965	421	1855		*	*
14x12	324	305	1029	1029	437	2620		*	*
16x14	375	324	1130	1130	475	3500		*	*
18x16	425	375	1219	1219	563	4970		*	*
20x18	473	425	1321	1321	617	7500		*	*
24x20	572	473	1549	1549	698	11000		*	*

* For weight consult the PARS PANGAN



PARS PANGAN COMPANY

Ball valve manufacturer

Optional Features

Stem Extensions

PARS PANGAN valves can be provided with optional stem extensions to permit buried or underground installation in remote or inaccessible areas.

When used for buried valve service, the stem extension can be furnished "Water right" and the piping of the grease injection system will also be extended.

When ordering extensions, please specify the distance required from the valve centerline to the top flange.

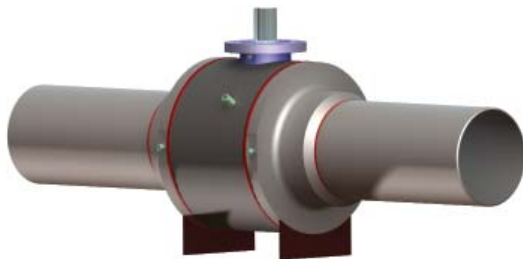

Transition Pieces (Pup Pieces)

PARS PANGAN can weld transition pieces to the valve during the manufacturing process.

Transition can be supplied to PARS PANGAN by the customer or be provided by PARS PANGAN to suit the customer's specifications.

PARS PANGAN offers a wide variety of weld procedures in accordance with international standards.

When ordering transition pieces, please specify the length of pups and matching details (i.e. pipe material & thickness).

Other ...

Upon request the Wrenches, the Gear-Boxes and the Actuators can be supplied with locking devices to suit the customer's specification.



Engineering Data / Torque Value & Mounting Flange Dimension

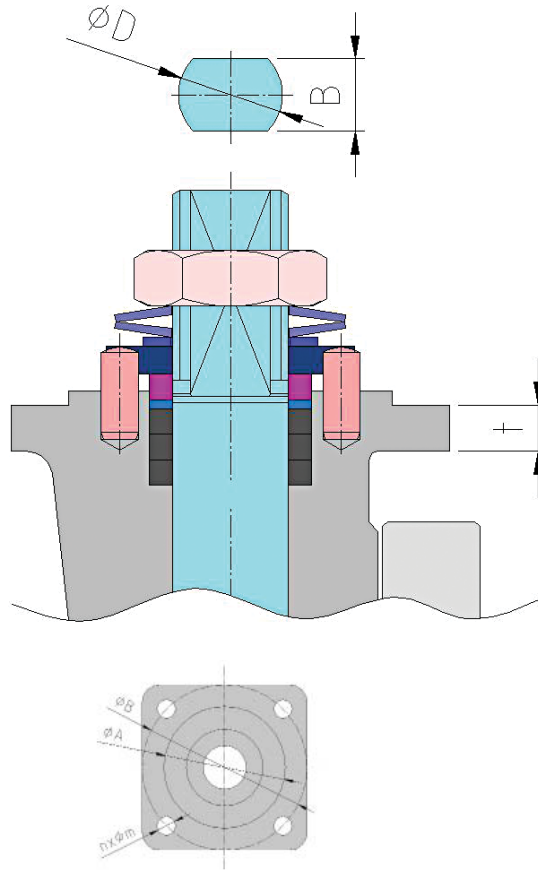

Size inch	Class	Torque N.m	Flange Dimensions mm				ISO 5211 Flang No.	B mm	D mm
			A	B	T	n-Md			
2x1-1/2	1500	6	55	70	9	4-8	F07	13	18
	300	9	55	70	9	4-8	F07	13	18
2	150	50	55	70	4	4-8	F07	13	18
	300	70	55	70	4	4-8	F07	13	18
3	150	90	70	102	10	4-10	F10	18	23
	300	120	70	102	10	4-10	F10	18	23
4	150	130	70	102	12	4-10	F10	20	26
	300	230	70	102	12	4-10	F10	20	26
6	150	560	85	125	16	4-12	F12	24	33
	300	930	85	125	16	4-12	F12	24	33
8	150	980	85	125	16	4-12	F12	38	30
	300	2197	85	125	16	4-12	F12	38	30



PARS PANGAN COMPANY
Ball valve manufacturer

Engineering Data / Torque Value & Mounting Flange Dimension

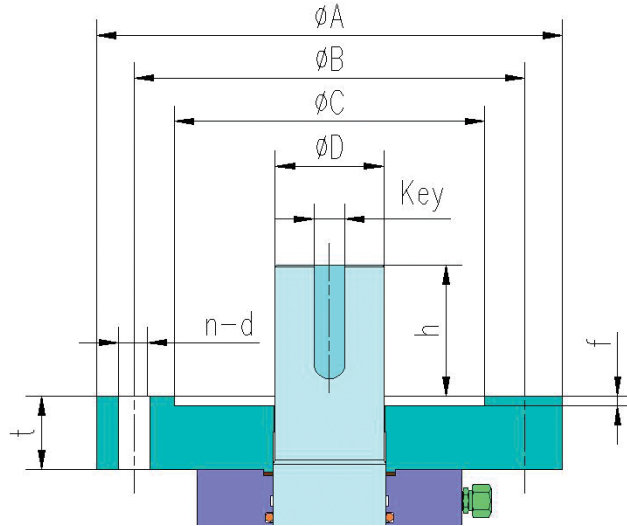

Size inch	Class	Torque N.m	Flange Dimensions mm						ISO 5211 Flange No.	key size DIN 6885 b*h*l	D mm	h mm	H mm
			A	B	C	f	t	n-d					
2	150	50	125	102	70	4	15	4-12	F10	C6*6*30	19	30	128
	300	60	125	102	70	4	15	4-12	F10	C6*6*30	19	30	126
	600	90	125	102	70	4	15	4-12	F10	C8*7*30	24	30	126
	900	200	150	125	85	4	18	4-14	F12	C8*7*30	30	31	140
	1500	320	150	125	85	4	18	4-14	F12	C8*7*30	30	31	139
3	150	60	125	102	70	4	18	4-12	F10	C8*7*30	24	32	144
	300	80	125	102	70	4	18	4-12	F10	C8*7*30	24	32	144
	600	180	150	125	85	4	18	4-14	F12	C8*7*40	30	41	169
	900	427	175	140	100	5	20	4-18	F14	C10*8*55	35	52	179
	1500	500	175	140	100	5	15	4-18	F14	C12*8*50	40	50	187
4	150	110	125	102	70	4	18	4-12	F10	C8*7*30	24	32	167
	300	210	150	125	85	4	18	4-14	F12	C8*7*40	30	38	189
	600	480	175	140	100	5	20	4-18	F14	C10*8*55	35	51	191
	900	790	175	140	100	5	15	4-18	F14	C12*8*50	40	48	201
	1500	1200	210	165	130	6	35	4-22	F16	C14*9*50	50	68	225
6	150	314	175	102	100	5	15	4-18	F14	C12*8*50	40	48	234
	300	525	175	125	100	5	15	4-18	F14	C12*8*50	40	48	234
	600	908	210	140	130	6	33	4-22	F16	C14*9*50	50	50	225
	900	1200	300	140	200	6	41	4-18	F25	C18*11*70	60	95	267
	1500	2900	300	165	200	6	47	4-18	F25	C20*12*90	70	91	273

Engineering Data / Torque Value & Mounting flange Dimension

Size inch	Class	Torque N.m	Flange Dimensions mm						ISO 5211 Flange No.	key size DIN 6885 b*h*l	D mm	h mm	H mm
			A	B	C	f	t	n-d					
8	150	622	210	165	130	6	33	4-22	F16	C14*9*50	50	51	259
	300	985	210	165	130	6	33	4-22	F16	C14*9*50	50	51	259
	600	2150	300	254	200	6	41	8-18	F25	C18*11*70	60	71	290
	900	3500	300	254	200	6	47	8-18	F25	C20*120100	70	103	312
	1500	5500	300	254	200	6	48	8-18	F25	C22*14*100	80	100	310
10	150	850	210	165	130	6	33	4-22	F16	C14*9*50	50	52	310
	300	1810	300	254	200	6	41	8-18	F25	C18*11*70	60	71	329
	600	3050	300	254	200	6	47	8-18	F25	C20*12*100	70	101	341
	900	5000	300	254	200	6	48	8-18	F25	C22*14*140	80	138	350
	1500	11000	300	254	200	6	48	8-18	F25	C28*16*140	100	140	363
12	150	1200	300	254	200	6	41	8-18	F25	C18*11*70	60	74	367
	300	2510	300	254	200	6	47	8-18	F25	C20*12*100	70	101	377
	600	4300	300	254	200	6	47	8-18	F25	C20*12*100	70	101	377
	900	9000	300	254	200	6	48	8-18	F25	C28*16*140	100	138	407
	1500	16000	350	298	230	6	48	8-22	F30	C32*18*150	120	154	421
14	150	1600	300	254	200	6	47	8-18	F25	C20*12*100	70	103	408
	300	3200	300	254	200	6	47	8-18	F25	C20*12*100	70	103	408
	600	7200	300	254	200	6	48	8-18	F25	C22*14*100	80	102	406
	900	15300	350	298	230	6	48	8-22	F30	C32*18*180	120	179	457
16	150	2800	300	254	200	6	48	8-18	F25	C22*14*100	80	98	442
	300	5350	300	254	200	6	48	8-18	F25	C22*14*100	80	102	436
	600	8900	300	254	200	6	48	8-18	F25	C28*16*140	100	142	446
	900	15300	350	298	230	6	48	8-22	F30	C32*18*180	120	179	457
18	150	3400	300	254	200	6	48	8-18	F25	C22*14*100	80	100	469
	300	5510	300	254	200	6	48	8-18	F25	C28*16*140	100	140	483
	600	13500	350	298	230	6	48	8-22	F30	C32*18*150	120	149	486
	900	21800	350	298	230	6	52	8-22	F30	C32*18*180	120	179	516
	1500	32000	415	356	260	6	52	8-22	F35	C36*20*220	140	219	563
20	150	4200	300	254	200	6	48	8-18	F25	C22*14*100	80	98	511
	300	7800	300	254	200	6	48	8-18	F25	C28*16*140	100	140	522
	600	18000	415	356	260	6	48	8-33	F35	C32*18*180	120	179	521
	900	29000	415	356	260	6	52	8-32	F35	C36*20*220	140	220	567
	1500	54000	415	356	260	6	52	8-33	F35	C36*20*210	140	209	796
24	150	5400	300	254	200	6	48	8-18	F25	C28*16*140	100	142	592
	300	9400	350	298	230	6	48	8-22	F30	C32*18*150	120	150	600
	600	21000	415	356	260	6	52	8-33	F35	C36*20*210	140	212	631
30	600	52000	415	356	260	6	52	8-33	F35	C36*20*210	140	209	796



PARS PANGAN COMPANY

Ball valve manufacturer

Engineering Data / APPLICABLE STANDARDS

ASME – AMERICAN NATIONAL STANDARDS INSTITUTE/ASME – AMERICAN SOCIETY OF MECHANICAL ENGINEERS

B 1.20.1	- Pipe Threads, General Purpose	B 31.3	- Chemical Plant and Petroleum Refinery Piping
B 16.5	- Pipe Flanges and Flanged Fittings	B31.4	- Liquid Petroleum Transportation Piping Systems
B 16.10	- Face to Face and End to End Dimension of Valves	B31.8	- Gas Transmission and Distribution Piping Systems
B 16.25	- Butt-Welding End	B 46.1	- Surface Texture (Surface Roughness, Waviness, and Lay)
B 16.34	- Valves – Flanged, Threaded and Welding End	ASME	- Boiler and Pressure Vessel Code – Section V, VIII & IX

API – AMERICAN PETROLEUM INSTITUTE

Spec. 6D	- Specification for Pipeline Valves	Std. 5B	- Treading Gaging and Tread Inspection of Casing and Line Pipe Treads
Spec. 6FA	- Specification for Fire Test for Valves	Spec. 5L	- Specification for Line Pipe
Std. 598	- Valve Inspection and Test		
Std. 607	- Fire Test for Soft Seated Ball Valves		

ASTM – AMERICAN SOCIETY FOR TESTING AND MATERIALS

BRITISH STANDARD

BS 1503	- Specification for Steel Forging for Pressure Purposes	BS 5404	- Flanges and Bolting for Pipes, Valves and Fittings
BS 1560	- Steel Pipe Flanges and Flanged Fittings	BS 5351	- Steel Ball Valves for Petroleum, Petrochemicals and Allied Industries
BS 2080	Face to Face, Center- to – Centre, End – to – End and Centre – to – End Dimension of Flanged and Butt- Welding End Steel Valves for the Petroleum, Petrochemical and Allied Industries	BS 6755 Part 2	Testing of Valves: Specification for Fire Type Testing Requirements
BS 3239	- Carbon Steel Pipe Flanges for the Petroleum Industry		

MSS-SP – MANUFACTURERS STANDARDIZATION SOCIETY OF THE VALVE FITTING INDUSTRY

SP -6	- Standard Finish for Contact Face of Pipe Flanges and Connecting End Flanges of Valves and Fittings	SP -61	- Hydrostatic Testing Steel valves
SP -25	- Standard Marking System for Valves, Fittings, Flanges and Unions	SP -72	- Ball Valve with Flanged or Butt Welding Ends for General Service
SP -44	-Steel Pipe Line Flanges	SP -82	- Valve Pressure Testing Methods
SP -45	- By Pass and Drain Connection Standard		

NACE – NATIONAL ASSOCIATION OF CORROSION ENGINEERS

MR-01-75	- Sulfide Stress Cracking Resistant Material for Oil Field Equipment	MT-01-77	- Laboratory Corrosion Testing of Metals for the Process Industries
----------	--	----------	---

How To Order

PARS PANGAN

figure Numbers are designed to cover essential features.

When ordering, please show figure numbers to avoid misunderstanding of your requirements. However a detailed description must accompany any special orders.



Following descriptions provide a basic guideline in valve specification:

1 Valve Size

2 Symbol for ball valve type

Symbol	Type
B	2-Pcs Floating type in casting
BT	2 -Pcs side entry Trunnion Mounted type
BS	3 -Pcs side entry Trunnion Mounted type
WB	Fully welded side entry type

3 ANSI Class

Code	1	3	6	8	9	15
Class	150	300	600	800	900	1500

4 End Connection

Symbol	End
R	Raised face flanged end
J	RTJ flanged end
B	Butt-welding end
S	Socket welding end
N	Screwed end

6 Trim Code

Code	Material
40	ASTM F304/R. RPTFE
41	ASTM F316/R. RPTFE
42	CR13/R. PTFE
43	CR13/A105 or WCB ENP/R. RPTFE
45	ASTM F316L/R. PTFE
49	LCC/R. RPTFE
52	ASTM F304L/R. RPTFE
53	C.S/A105 ENP/AISI 4140+ENP STEM/R. PTFE
65	17-4PH/R. PTFE



Ball Valve 48" - 150



PARS PANGAN COMPANY

Ball valve manufacturer

5 Shell Material

Material	Symbol	Classification Steel	ASTM REF.	Recommended Temperature limits		Application
				°C	°F	
WCB (A 105)	A	Carbon	A216 Grade WCB	-29 to 425	-20 to 800	Steam ,Water, Oil ,vapor ,gas and general service
LCB (LF2)	B	Carbon	A352 Grade LCB	-46 to 350	-50 to 650	Low temperature
LCC	C	Carbon	A352 Grade LCC	-46 to 350	-50 to 650	
WC6 (F11)	D	Chromium Moly. 1.25% Cr , 0.5% Mo	A217 Grade WC6	-29 to 590	-20 to 1100	Steam ,Water, oil, oil vapor, gas and general service
WC9 (F22)	E	Chromium Moly. 2.25% Cr , 1% Mo	A217 Grade WC9	-29 to 590	-20 to 1100	
C5	F	Chromium Moly. 5% Cr , 0.5% Mo	A217 Grade C5	-29 to 650	-20 to 1200	Corrosive/erosive oil
CF8M (316)	G	Stainless 18% Cr , 10% Ni , 2% Mo	A351 Grade CF8M	-196 to 815	-320 to 1500	refinery service
CF8 (304)	H	Stainless 18% Cr , 10% Ni	A351 Grade CF8	-196 to 815	-320 to 1500	High and low temperature corrosion resistance
CF3M (316L)	I	Low Carbon Stainless 18% Cr , 10% Ni , 2% Mo	A351 Grade CF3M	-196 to 815	-320 to 1500	
CF3 (304L)	J	Low Carbon Stainless 18% Cr , 10% Ni	A351 Grade CF3	-196 to 815	-320 to 1500	Cryogenic service is also available upon request
CN7M Alloy 20	P	Stainless 19% Cr , 29% Ni	A351 Grade CN7M	-196 to 425	-320 to 800	Corrosion resistance

7 Others

Symbol	Description
	Lever handle
G	Gear operator
R	Reduce bore
M	Electric actuator
P	Pneumatic actuator
EB	Extended Bonnet
ES	Extended Spindle
I	Indicator
NC	NACE MR 0175 Requirement
GL	Seat and stem injection







2nd Floor, No.5, Nikraay St., Shams Tabrizi St.
Mirdamad Blvd., Tehran1919914615, Iran.

Tel.: + 98(21) 2222 5849, 2226 3915
+ 98(21) 2227 4929-30
Fax: + 98(21) 2227 8440

www.parspangan.com
sales@parspangan.com
manager@parspangan.com